

FROM GEOFF 12/12/2025

Hi Chris,

If the Flexible Hub Bushing is well worn & the loading has come onto the Aft Peek Bushing it maybe worn also.

A possible reason for a loose(wiggle) propeller install on your Saildrive is the Flexible Hub Bushing is worn, the Peek Bushings are worn, the Inner Hub either being worn where the Peek Bearing locate, the Blade assembly ID hole being worn where the Peek bearing locate or the fit on the saildrive spline.

If the prop was used for a period of time with a worn Flexible Hub Bushing – Item #2.2, the loading would be on the Peek Bushings (Item #2.1 & 2.3). The Peeks therefor wear as does the Inner Hub piece(#2) where the Peek bushing locate.

The Inner Hub – Item #2, the OD ends where the Peeks locate have a measurement of 34.97mm (Fwd.) & 39.97mm (Aft) respectively.

What is your measurements on the Inner Hub where the Peeks locate?

Measurements:

Inner hub (3 blade) - outside dia. measures
Small end 35 mm, Large end 40 mm, tolerance minus 0.3 mm

Retaining Cap Ring – Item #1
Inside 50 mm, tolerance plus 0.3 mm

Peek Bushing 50 – Aft – Item #2.3 - 14004300.
Inside dia. 35 mm, Outside dia. 50 mm tolerance plus/minus 0.3 mm

Peek Bushing 40 – Fwd. - Item #2.1 – 14004400.
Inside dia. 40 mm, Outside dia. 50 mm plus/minus 0.3 mm

Guideline for GORI Sail Drive Propeller - Wear and tear at PEEK bushings

Hub BBB75S – 15” – 16.5” Dia.
Max theoretical angular movement on new hub 0,40 deg.
Service needed when angular movement reaches 0,80 deg.
On open propeller that's correspond to 3 mm tip movement
for max propeller diameter of 16,5".

The Saildrive Flexible hub bushing has most likely worn also - due to inertia, shock loading, hours of use & it's done its job as designed.

The saildrive hub bushing & isolation bushings wear due to use, inertia & shock torque. It's there as mandated by the engine manufacturers to protect the saildrive drive train bevel gear and shaft components.

The rubber Flexible Bushing acts as a torsion damper in the unlikely event of the propeller striking a solid object under power to save the saildrive leg shaft & gears. The rubber insert will protect the saildrive in this instance and will help absorb the impact. These rubber Flexible Bushings should be replaced inspected & periodically.

The hub of the GORI approved saildrive incorporates a flexible bushing that absorbs the shock & electrically insulates the propeller from the saildrive leg. GORI saildrive hubs conform to the requirements for the static torsional spring constant (stiffness) of the rubber bushing and moment of Inertia of the propellers & shock torque during engagement in forward and reverse of the saildrive.

This is necessary & required by the engine manufacturers for an approved propeller so as not invalidate your engine & saildrive warranty.

The flexible rubberised bushing absorbs shock & inertia and is made to withstand the max. allowable shock torque & max allowable Moment of Inertia as set by the engine manufacturers spec's.



Gori 3-Blade Saildrive Installation Instructions

Table of Contents

Gori 3-Blade Saildrive Installation Instructions.....	2
Parts List.....	2
Schematic Drawings	3
Saildrive Nut Socket Sizes	4
Torque Settings.....	4
Installing the Propeller	5
Removing the Propeller	7
Replacing the Aft Zinc.....	7
Replacing the Forward Collar Zinc.....	7
Replacing Flexible Stops.....	8
Removing the blades from the Blade Housing	10
Operating Instructions	11
Ahead	11
Astern.....	11
Overdrive	11
Sailing	12
Cleaning and Maintenance.....	13
Annual Maintenance.....	13
Underwater Installation	13

Parts List

1.	Retaining Cap	11.	Blade Pins (3 x each)
2.	Inner Hub	11.1	Outside locking bolts for Blade pins
2.1	Peek Bushing - Fwd	12.	Propeller blades (3 x each)
2.2	Flexible Hub Bushing	13.	Gear Wheel
2.3	Peek Bushing - Aft	14.	Spacer
3.	Shaft Nut	15.	Flexible Stops (3 x each)
4.	Washer for nut-locking bolt	16.	C-Spanner
4.1	Nut locking bolt	17.	Fwd Zinc ring anode
5.	Locking bolts for retaining cap	17.1	Bolts for Fwd zinc ring anode
6.	Blade housing	18.	Allen key 4mm
7.	Aft Zinc anode	19.	Allen key 5mm
8.	Fixing bolt for zinc anode	20.	Allen key 6mm
9.	Threaded pin on 18-20" dia. only	21.	Locking glue / Loctite 243
10.	Fixing bolt for pins 18-20" dia. only		

Schematic Drawings

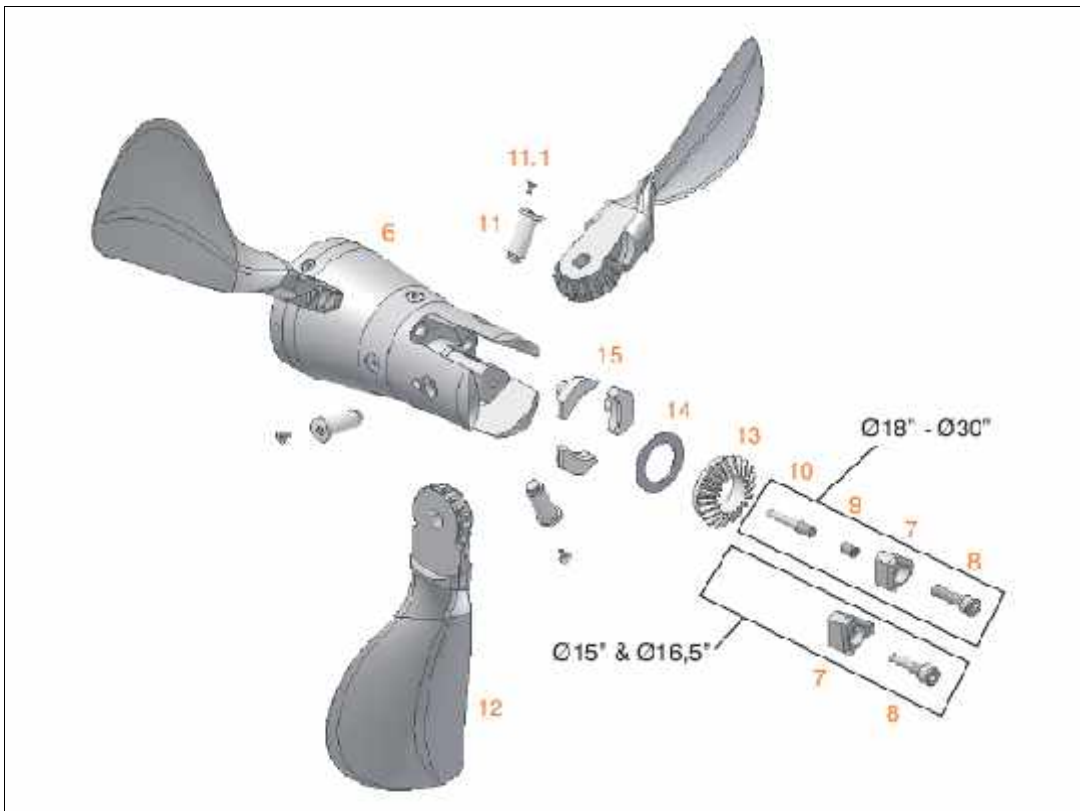
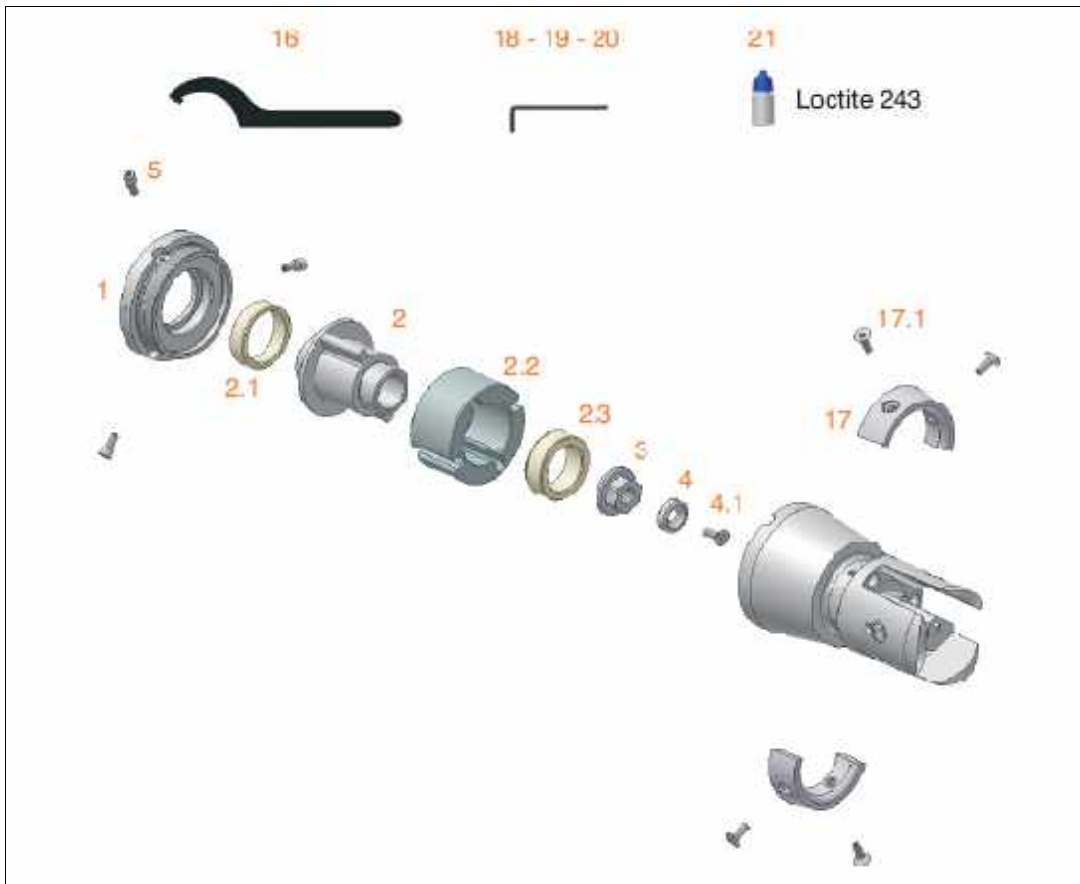

Saildrive Nut Socket Sizes

3-Blade ~ Saildrive	15" to 20" diameter	24 mm socket

Torque Settings

Saildrive Model	Fastener Type	Fastener Size	Torque
Yanmar SD20/25, 30/31, Volvo, Lombardini, Beta, Nanni, Technodrive SP60	Saildrive Nut	M16 X 2.0	45 ft/lb (60Nm)
Yanmar SD40/50/60	Saildrive Nut	M20 x 2.0	72 ft/lb (88- 98Nm)
[All]	Nut Locking Bolt	M8	9-10 ft/lb (15NM)

Installing the Propeller

The propeller is delivered assembled. This ensures that at the factory the propeller has been checked and balanced before shipping.

Warning ~ Do Not remove the blades from the blade housing when installing or removing the propeller from the shaft!

To remove blades – the center Fixing Bolt "MUST" be removed first!!!!

1. Remove the 3 x Allen head bolts (5) holding the retaining cap (1) in place.
2. Unscrew the retaining cap from the blade housing using the C-Spanner (16). The thread on the blade housing assembly (6) is a standard right to tight and left to loosen. Using the C-Spanner with handle out to Starboard/right side of propeller, tap the C-Spanner with a hammer to get the retaining cap started as it is torqued into place. The retaining ring unscrews forward.
3. The retaining cap and blade housing assembly (6), (*with blades installed*) are now separate.
4. Remove the inner hub (2), flexible hub bushing (2.2), and PEEK bushings (2.1, 2.3) from the blade housing (6). Wet/Lubricate flexible hub bushing with water/soap for ease of pulling out the spline piece (use pliers with protection) by pulling/wiggling the inner hub spline piece out.
5. Check the shaft nut (3) and the nut-locking bolt (4.1) screws onto the output shaft threads.

Do not use a petroleum product on Flexible Hub Bushing!

6. Ensure that the Saildrive spacer supplied with the saildrive unit is in place at the forward end of the output shaft. The forward face of the saildrive propeller hub presses against this saildrive supplied spacer to keep the retaining cap/blade housing clear of the saildrive leg zinc.
7. Lightly smear spline grooves and shaft with waterproof lithium anti-corrosion lubricant as specified by saildrive manufacturer.
8. Slide the retaining cap (1), PEEK bushing (2.1), inner hub (2), and PEEK bushing (2.3) on to the saildrive shaft, matching the splines on the output shaft with those in the inner hub (2).
9. Apply locking glue (Loctite 243) to the shaft and nut threads and install the GORI supplied nut (3) and tighten/torque (see above torque settings) the nut by either holding the hub with a strap wrench or holding the engine front pulley to get the required torque on the shaft nut. To tighten the nut to the specified torque for your saildrive model, move the shift lever to Ahead and hold the crankshaft V-Pulley clamp nut with a wrench to stop the propeller shaft from rotating. Put a dab on the shaft thread after the nut is torqued in place. This is required by Loctite. See above socket size.

The supplied Loctite 243 locking glue is "Blue" and is for disassemble of parts with hand tools. Loctite "Red" is permanent and requires heat to undo (450°F for 5 minutes). Applying locking glue correctly is important. The surfaces must be clean and degreased. Glue needs to be put in the hole as well as threads for blind holes such as with the Locking bolt.

It is very important to always use the Gori supplied propeller nut for the installation. An incorrect nut can lead to loss of the propeller, part of the propeller or cause an electrical connection between the propeller and the saildrive.

6. Install the two(2) nut locking setscrews into the two threaded holes in the nut aft face (supplied in parts bag) with Loctite applied to threads. Tighten. On older nut versions setscrew holes may not be present.
10. Smear Loctite 243 on the thread of the nut-locking bolt (4.1). Place the washer (4) into the shaft nut and then screw in the nut-locking bolt (4.1) using a 5mm Allen key (19). Tighten Locking Bolt (4.1) to 9-10 ft/lbs(15NM) of torque.
11. Install/slide the flexible bushing (2.2) onto the spline hub and slide/push/wiggle the complete blade housing assembly (6 thru 17.1), onto the flexible bushing (2.2), so that the 2 x security cams slide into the grooves of the flexible bushing (2.2). Wet the flexible hub bushing with water, silicone or soap liquid to allow it to slide in easily if necessary.

Do not use oil or any petroleum product on flexible hub bushing!

12. Continue to slide the blade housing onto the assembly until the thread of the retaining cap (1), and the blade housing (6) are touching. Smear threads of housing and retaining cap with waterproof lubricant/grease, Lanocoat, Tuffgel etc.
13. Screw the retaining cap (1) RH or clockwise onto the blade housing assembly (6). Screw in fully using the C-Spanner (16) tighten until the 3 x holes in the retaining cap are aligned with the 3 x half circle cutouts in the blade housing assembly. Use a hammer or C-Spanner for final tightening of the retaining cap to align bolt holes.
14. Using the Loctite-243 (21), re-install the 3 Allen head bolts (5) using the 5mm Allen key (19), into the holes and tighten firmly.
15. Check that the blades will move freely from forward to reverse.

Your Gori is water lubricated. At hauling, after cleaning, before storage, put a light smear of a waterproof grease over the blade teeth, blade cheeks, gear wheel (13) & blade fork housing (6) contact points. This will allow you to check blade operation and stop oxidization of the metal when out of the water.

Removing the Propeller

Warning ~ Do Not remove the blades from the blade housing when removing the propeller from the shaft

1. Remove the 3 x Allen head bolts (5), from the retaining cap (1).
2. Using the C-Spanner (16), unscrew the retaining cap so that it separates from the blade housing assembly (6). Using the C-Spanner with handle out to Starboard/right side of the propeller, tap the C-Spanner with a hammer to get the retaining cap started as it is torqued into place.
3. Remove the blade housing assembly by pulling off/wiggling off from the flexible bushing (2.2) and shaft inner hub (2). These two items along with the bushings (2.1, 2.3) will remain on the output shaft. Water, silicone or soap liquid can be used to lubricate the flexible bushing (2.2) to facilitate blade housing removal.

Do not use oil or any petroleum product on Flexible Bushing!

4. Unscrew the nut-locking bolt (4.1) with the washer (4) using a 5mm Allen key (19).
5. Unscrew the shaft nut (3) counterclockwise. It will be necessary to lock the output shaft when undoing the shaft nut. To do this either put the engine into reverse or use a strap wrench to hold the inner hub (2).
6. Slide/pull the inner hub (2), flexible bushing (2.2), Peek bushings (2.1 and 2.3), and retaining cap (1) off the output shaft. Make sure the saildrive spacer is retained on shaft.

Replacing the Aft Zinc

Note: Gori zincs have metal inserts to ensure positive contact at all times even after zinc erodes.

This should be done if more than 50% of the zinc (7), has been eroded away.

1. Undo the Allen head bolt (8) and remove the old zinc (7).
2. Clean the zinc contact surface on the blade housing to ensure clean strong bond with the new zinc.
3. Replace the zinc with a new zinc. Locate and align the zinc with the pin on the end of the blade housing. Note: on 15"-16.5" diameter propellers this bolt retains the blade pins so use the Gori zinc and bolt.
4. Use the new Allen head bolt supplied. Smear with loctite (supplied) before re-installing the bolt.
5. Check that the zinc is correctly aligned and blades swing through completely from forward to reverse. If zinc and blades contact each other, realign zinc (tap with hammer to align).

Replacing the Forward Collar Zinc

This should be done if more than 50% of the zinc (17), has been eroded away.

1. Remove the 4 x Allen-head bolts (17.1) and remove the old zinc.

2. Clean the surface of the propeller hub to ensure a good clean contact between the hub and the new zinc
3. Install the new zinc (17) using the Loctite 243 (supplied) on each of the 4 x Allen-head bolts

Replacing Flexible Stops

The Replaceable Flexible Stops serve to minimise noise and absorb blade opening shock load at start-up and when going into reverse and Overdrive. There is no standard time/hours for replacement, it depends on the amount of wear due to engine hours, blade loading and inertia.

The stops "sit" (are installed) under the bevel of the center gear wheel between each blade slot with their round tit pressed/located into a hole (see schematic). The propeller does not need to be disassembled to remove and install new Flexible Stops, however the task is easier if the propeller is disassembled - blades and gear wheel removed.

For a Disassembled propeller with Blades removed

1. To remove old stops (15), use a flat head screwdriver positioned under the stop and pry the stop up and out of the retaining hole.
2. Clean the hole and surrounding area.
3. Ensure the "tit" hole is clean.
4. Apply a smear of a lubricant – lite oil/grease/dish washing liquid - to the tit.
5. To install new stops, locate the stop tit over the hole.
6. Press the stop into the hole ensuring it is fully seated. Use a wood dowel and tap down to press the stop fully home in the hole.
7. Reassemble propeller making sure the PEPT spacer and center gear wheel are positioned and turn freely.

For a non-disassembled propeller with Blades installed

1. Move the blades into the fully folded position, exposing the old stops (15).
2. Use a flat head screwdriver positioned under the stop and pry the stop up and out of the retaining hole.
3. Clean the hole and surrounding area.
4. Ensure the "tit" hole is clean.
5. Apply a smear of a lubricant – lite oil/grease/dish washing liquid - to the tit and to the back bevel inside face to the gear bevel.
6. Ensure the blades are in the fully folded position, exposing the retaining slot "tit" holes.
7. To install new stops, locate the stop tit over the hole.
8. Press/work the stop into the slot between the gear teeth by moving the blades slightly back and forth, swivelling them open and closed, to obtain the best angle and position over the hole.
9. The stop will be sitting above the gear wheel. Use a flat blade screwdriver to position and hold the stop tit over the hole.

10. Bring the blade 'down' into the fully open position (with a bit of force), "popping" the stop into position under the gear wheel bevel and fully into the hole. Alternatively using a wood dowel over the stop, tap the stop down so it 'pops' under the center gear bevel.

Notes:

- If the stops are loaded left and then right, the stops may get twisted causing the teeth and stops to rub on one end of the stop.
- If loaded with stop tit pointed upwards, and then pushed down to rotate the entire stop, as in pushing the tit on the stop downwards along the centerline of the stop, this keeps the stop better aligned with the gears as it gets its tit inserted (pushed) into the housing. Use the blade of the prop plus a flathead-screwdriver blade to do this to fully insert the tit into the housing.

Distributed By

AB Marine, Inc ▪ 747 Aquidneck Ave ▪ Middletown ▪ RI 02842
Tel: 401-847-7960 ▪ Fax: 401-849-0631
Email: Sales@AB-Marine.com ▪ Website: www.AB-Marine.com

Removing the blades from the Blade Housing

This must only be done when cleaning and full service of the propeller is required. Blades are not removed for the installation and removal of the propeller.

To remove blades – the center Fixing Bolt "MUST" be removed first!

1. Remove the zinc centre bolt (8) and the zinc anode (7), using a 5mm Allen key (19).
2. On propellers 18.0" diameter and larger it will also be necessary to: Remove the threaded pin (9) using a 6mm Allen key (20), then Remove the fixing bolt (10) using a 5mm Allen key (19).

Failure to remove all these pins (8-9-10) first, will result in damage to the internal threads of the blade pins (11) & blade housing.

3. Remove the blades.
4. Remove the flexible stops (15) using either a flat blade screwdriver or pliers.
5. Remove the gear-wheel (13) and the spacer (14).
6. Remove the flexible stops (15) if required using either a flat blade screwdriver or pliers.
7. The blade housing (6), the pins (11) and the propeller blades (12) are numbered 1,2 & 3 and must be matched when reassembling. When re-mounting the blades to the housing it is important to apply loctite-243 to all of the following: blade pins and external locking screw/bolt (11 & 11.1), fixing lock bolt (10), threaded pin (9), zinc anode bolt (8).
8. On older models without the external lock bolt (11.1), the blade housing (6) and the blade pin head (11) are marked with a hatch line and must align when remounting.
9. The fixing bolt (8) on 15-16.5" dia or (10) on 18" dia. & larger, locates in the ½ moon cut out in the blade pin end and stops the blade pin from unscrewing/coming out.
10. The fixing lock bolt (10) or the zinc fixing bolt (8) are the very last items to be reassembled.
11. Be sure that all components fit back together and that the blade pins (11) are located as before removal as they are indexed inside the hub to lock bolts (10 +8) by the external Lock Bolts (11.1) or the hatch line.

Note:

- If more than 50% of either of the zincs (7-17) has been eroded away they should be replaced.
- If the gear wheel (13) has been damaged or worn...it should be replaced
- If the flexible stops (15) have been damaged or worn...they must be replaced.
- Apply a "lite" smearing of a lithium based waterproof grease to all blade, hub fork & gear teeth contact surfaces at haul out to stop oxidizing & just prior to launch.

Operating Instructions

The Gori 3-blade propeller blades fold inside out when going from forward to reverse, presenting the identical leading edge and blade shape in reverse as in forward. When in reverse position, the blades have a greater pitch by approximately 2.0~3.0 inches. These two positions provide two forward pitch options: standard forward and overdrive forward

By going forward with the blades in the reverse position, the Gori 3-blade achieves its second forward pitch, or overdrive. For example, in forward a 17 inch pitch is a 19 inch pitch in reverse, thus in standard forward your 17 inch pitch propeller will be 19 inch pitch in overdrive.

Standard forward pitch allows the engine to perform to the required engine manufacturer's RPM.

The higher overdrive pitch will absorb approximately 300~600 additional engine RPM. This produces increased thrust & power, higher boat speed, at the same RPM, or optionally can produce the same boat speed at a lower RPM.

Ahead

The propeller will operate in the standard forward setting when the blades open, due to the centrifugal force of the shaft when in gear.

Should you have backed out of your slip, and then engage forward, you be in overdrive. To go back to standard forward gear, simply move the shift lever into neutral for ~2 seconds (allowing the blades time to fold together) and then go back into forward. You will soon learn the difference between standard and overdrive by checking boat speed and engine RPM sounds.

When maneuvering around the marina you may well remain in overdrive. Therefore when leaving the marina and beginning your trip always check that you are in the drive position you want.

Astern

In the reverse position the blades swivel 180° opposite the forward position which ensures the same blade shape and leading edge to the water, resulting in higher efficiency. This will also eliminate prop-walk when maneuvering in reverse in the marina. If the boat has not been used for sometime, it is wise to shift cautiously between forward and reverse a few times before going out sailing in order to clean the teeth of the blades and the gears from further fouling.

In the reverse position the pitch on the blades is at a greater angle then when in standard forward. This is done purposely as many transmissions have higher ratios in reverse then forward and so require a greater pitch to take into account the slower shaft rpm when in reverse.

Overdrive

As mentioned above, this position is obtained when the blades are set in the reverse position but the blades and shaft are rotating forward. In this situation you will have a propeller with an increased pitch. Overdrive allows a lower cruising RPM for the same boat speed. It will be as much as 300~600 engine RPM lower than when in standard forward.

How to get into or out of overdrive?

Overdrive » standard drive: Be sure that you are moving ahead at around 3~4kts ... now move your shift lever into the neutral position (if you have dual lever control then reduce RPM accordingly) ... wait several seconds, to allow the blades to fold to their sailing position or "bump" into reverse for a second or two ... now reengage forward with the shift lever (and if necessary increase engine RPM with the second lever). You should now be in standard forward and this will show with increased engine RPM for the same speed, which perhaps was not attainable, while in "overdrive".

On some larger vessels it has been found that to stop the shaft rotation even more quickly than as above ... simply put the shift lever into the reverse position momentarily, this will cause the shaft to stop its freewheeling more quickly than just relying on the water flow. Once the shaft has stopped re-engage forward and increase engine RPM.

Standard » overdrive: Reduce RPM and move the shift lever into neutral ... now go into reverse and increase engine RPM to around 1000-1800 RPM. This will set the blades into reverse. Now go from reverse to forward position without hesitation ... you will now be in "overdrive". By moving the shift lever smartly from reverse thru to forward the shaft and blades will not have the opportunity to stop and the water flow fold the blades as for sailing ... thereby remaining open in the reverse or "overdrive" position. Do not press the engine to the max RPM when in "overdrive" as this will result in overloading – Stay approx. 600+ below continuous RPM. Only use "overdrive" when motoring in clam weather or when motor-sailing.

****Gori Propeller disclaims responsibility for any damage caused by overloading the engine. In case of doubt about engine loading, contact the authorized engine service agent and Gori Propeller.***

Sailing

When sailing, the blades will fold and the shaft will not spin, giving you less drag and more speed. When starting to sail, to fold the Gori blades immediately, go into reverse for a brief second, then back to neutral. This stops the shaft immediately and the blades will fold. Turn off the engine. With mechanical transmissions you can put the shift lever into reverse – see your engine manufacturer's instructions. Hydraulic transmissions will not rotate when under sail with the Gori propeller.

WARNING!!!

- Do not start the engine while the boat is out of the water
- The prop may have sharp edges... be careful not to cut yourself
- Make sure the blades do not open or close suddenly and trap your fingers
- Stop the engine before diving or swimming in the vicinity of the boat
- Propeller blades can cause considerable damage when rotating ... be careful
- Do not remove fish nets, rope or similar from the propeller with the engine running
- Check that the propeller works in both forward and reverse before each trip.
- If any strange sounds or vibrations are noticed coming from the propeller stop the engine and investigate the reasons/solve the problem.
- In case of problems in connection with the mounting, use or other function of the propeller, contact Gori Propeller or the local agent/importer.

Cleaning and Maintenance

Annual Maintenance

1. Clean your propeller with an acid cleaner such as Barnacle Buster – per MSDS, use 85% phosphoric acid with concentration of 5%-20%. When pressurewashing, using Scotchbrite, wire brush/wheel, bead blaster or 120 grit paper, be mindful of, i.e., do not “attack”, the blade edges.

Propeller blades “work” with attached water flow - 1mm of growth on a blade causes loss of approximately 12% of its efficiency - so keep the blades clean.

2. Remove any growth on the blade gear teeth.
3. Smear with your finger a light coating of a Lithium based waterproof grease on the teeth/forks/blade root - the contact faces and moving parts. This stops surface oxidizing over the winter and ensures smooth operation.
4. If you have disassembled your GORI make sure that the Jacket/Blade assembly threads are greased so that any calcium build up is negated in the thread.
5. Change the anodes at 55% wastage, i.e. 45% is remaining ([Saildrive and 3-blade](#))
6. Check the flexible stops ([3-blade](#)) for wear
7. Paint with hard anti-foiling paint, ablative antifouling and a silicon based epoxy (i.e. PropSpeed), zinc spray or any other product that says it negates/stops growth (Lanolin etc) can be used.
8. Ensure that the coating is smooth and does not impair the operation of the blades (gear teeth, bearings, seals etc).

Underwater Installation

Underwater installation is NOT recommended, but can be accomplished by a skilled diver and appropriate tools and underwater fastener adhesives

Loctite 248 is a medium strength Threadlocker Stick that is sold to be used under water. Apply the 248 to clean dry threads out of the water and make sure the wax based product is thoroughly pushed into all of the threads (no air gaps) before taking the fastener below the water. It takes 24hrs for full cure after installation. Loctite 248 blue stick can be purchased from Fastenal <http://www.fastenal.com/web/locations.ex>

Vibra-Tite VC-3 is an automotive product that can be used under water. Apply to the fastener threads, let dry for 10-30 minutes and install below water. VC-3 is available from most auto parts stores - we have the VC-3 in stock (used with our Shaft Shark line cutter) and can ship the same day as your order.

Do Not Use regular thread locking glue not intended for use underwater – attempts to apply it under water will ultimately fail/wash off

[Gori 3-Blade Saildrive Propeller Installation and Maintenance Instructions, 3/31/2022]

Bondchem WT03 Thread Locker liquid glue, supplied by Gori, and Loctite Blue 242 liquid (or Red) cannot be used under water - they cure anaerobically and must be applied to a clean dry surface as per their instructions.

Distributed By
AB Marine, Inc ▪ 747 Aquidneck Ave ▪ Middletown ▪ RI 02842
Tel: 401-847-7960 ▪ Fax: 401-849-0631
Email: Sales@AB-Marine.com ▪ Website: www.AB-Marine.com