

3YM30

	Page
Engine Specifications	2
Marine Gear / Sail Drive Specifications	3
Fuel System Specifications	4
Cooling System Specifications	4
Air Intake and Exhaust Specifications	5
Alarm System Specifications	5
Engine Outline with KM2P-1.....	6
Engine Outline with SD20.....	7
Piping Diagram	9
Electrical System	10
Performance Curves.....	15
Controls	16
Power Take-Off	18
Engine Mount Specifications	19
Flexible Mount Distortion	21
Cold Starting Aids.....	22
Air Venting	22
Water Heater Tank Connection	22
Optional Accessories.....	22

3YM30

Engine Specifications

Parameter	Data
Configuration	4-cycle, Vertical, Water-Cooled Diesel
Crankshaft Rotation (Viewed from Stern)	Counterclockwise
Combustion System	Swirl Pre-Combustion Chamber
Aspiration	Naturally Aspirated
Number of Cylinders	3
Bore x Stroke	76 mm x 82 mm (2.9 in. x 3.2 in.)
Displacement	1.115 L (68.04 cu in.)
Continuous Rating Output at Crankshaft (at 3489 rpm)	20.1 kW* (27.3 hp metric)*
Brake Mean Effective Pressure (Continuous Rating Output)	0.62 MPa 6.31 kgf/cm ² (89.92 psi)
Piston Speed (Continuous Rating Output)(l)	9.54 m/sec. (31.3 ft/sec.)
Maximum Output at Crankshaft (at 3600)	22.1 kW* (30.0 hp metric)* or 21.3 kW** (29.0 hp metric)**
Brake Mean Effective Pressure (Maximum Output)	0.66 MPa* 6.72 kgf/cm ² * (95.73 psi)*
Piston Speed (Maximum Output)	9.84 m/sec. (32.28 ft/sec.)
High Idling Speed	3850 ± 25 rpm
Low Idling Speed	850 ± 25 rpm
Firing Order	^{240° 240° 240°} 1 - 3 - 2 - 1
Starter Motor	DC 12 V, 1.4 kW

Parameter	Data
Alternator	DC 12 V, 60A DC 12 V, 80A - Optional
Minimum Battery Capacity	DC 12 V, 64 Ah
Cooling System	Fresh water cooling by centrifugal fresh water pump and rubber impeller seawater pump
Coolant Capacity (Engine)	4.6 L (4.9 qt)
Coolant Recovery Tank Capacity	0.8 L (0.85 qt)
Engine Lubrication System	Forced lubrication with trochoid pump
Engine Oil Capacity at 8° Rake Angle (Effective / Maximum)	1.4 / 2.8 L (1.48 / 2.96 qt)
Engine Oil Capacity at 0° Rake Angle (Effective / Maximum)	1.5 / 2.5 L (1.59 / 2.64 qt)
Dry Weight (with KM2P-1)	133 kg (293 lb)
Dry Weight (with SD20)	157 kg (346 lb)
Recommended Installation Rake Angle	KM2P-1: 8°
	SD20: 0°
Maximum Installation Rake Angle	KM2P-1: 15°

Notes:

1. Rating condition:

- * Fuel temperature: 25°C at fuel pump inlet ISO 3046-1
- ** Fuel temperature: 40°C at fuel pump inlet ISO 8665
- Fuel density: 0.842 g/cm³ at 15°C

2. 1 HP (hp metric) = 0.7355 kW

Marine Gear / Sail Drive Specifications

Use the KM2P-1 or the SD20 with the 3YM30 engine. KM2P-1 is a parallel drive with a mechanical cone clutch and SD20 has a constant mesh gear with dog clutch.

KM2P-1

Parameter	Data
Reduction Ratio (Ahead)	2.21 / 2.62 / 3.22
Reduction Ratio (Astern)	3.06
Marine Gear Oil Capacity	0.3 L (0.32 qt)
Propeller Rotation (Viewed from Stern)	Clockwise
Dry Weight (without Engine)	10.3 kg (27.7 lb)

SD20

Parameter	Data
Reduction Ratio (Ahead)	2.64
Reduction Ratio (Astern)	2.64
Sail Drive Oil Capacity	Standard 2.2 L (2.3 qt)
	Long-reach 2.5 L (2.6 qt)
Propeller Rotation (Viewed from Stern)	Counterclockwise
Dry Weight (without Engine)	30 kg (66.13 lb)

Fuel System Specifications

Parameter	Data
Maximum Fuel Feed Pump Suction Head	0.5 m (19.69 in.)
Maximum Fuel Feed Pump Discharge Volume (Engine at 3000 rpm)	9.2 L/min. (2.44 gal/min.)
Maximum Fuel Feed Pump Discharge Pressure (Engine at 3000 rpm)	12.73 kPa (1.85 psi)
Fuel Inlet Pipe Connector Outer Diameter	8.3 mm (0.326 in.)
Fuel Return Pipe Connector Outer Diameter	8.0 mm (0.315 in.)
Fuel Consumption at Continuous Rated Output	6.7 L/hr (1.77 gal/hr)

Cooling System Specifications

Parameter	Data
Maximum Seawater Pump Suction Head	0.5 m (19.69 in.)
Seawater Inlet Pipe Connector Outer Diameter	17.3 mm (0.682 in.)
Thermostat Operating Temperature (Full Open)	85°C (185°F)
Thermostat Operating Temperature (Opening)	70 - 72°C (158 - 161.6°F)
Maximum Overflow Pipe Length (Coolant Recovery Tank to Filler Cap)	1.0 m (39.37 in.)
Maximum Overflow Pipe Outer Diameter (Coolant Recovery Tank to Filler Cap)	9 mm (0.355 in.)
Water Heater Tank Connector Thread Size	RC 3/8 (inlet) M16 (outlet)

Air Intake and Exhaust Specifications

Parameter	Data
Exhaust Pipe Outer Diameter Connection	50.8 mm (2.0 in.)
Minimum Engine Room Fresh Air Exchanges (Ventilator Capacity)	5.5 cu m/min. (194.23 cu ft/min.)
Maximum Back Pressure (measured within 250 mm [9.8 in.] of exhaust manifold inlet)	1500 mmAq 14.7 kPa (0.15 kgf/cm ²)
Maximum Output Exhaust Temperature (measured within 250 mm [9.8 in.] of exhaust manifold inlet)	600°C (1112°F)
Maximum Turbocharger Boost Pressure	-
Maximum Engine Room Ambient Temperature	60°C (140°F)

Alarm System Specifications

Parameter	Data
Coolant Alarm Switch Operating Temperature	ON: 93 - 97°C (199.4 - 206.6°F) OFF: 88 - 93°C (190 - 199°F)
Lube Oil Switch Operating Pressure	9.8 - 29.4 kPa (1.43 - 4.27 psi)

Engine Outline with KM2P-1

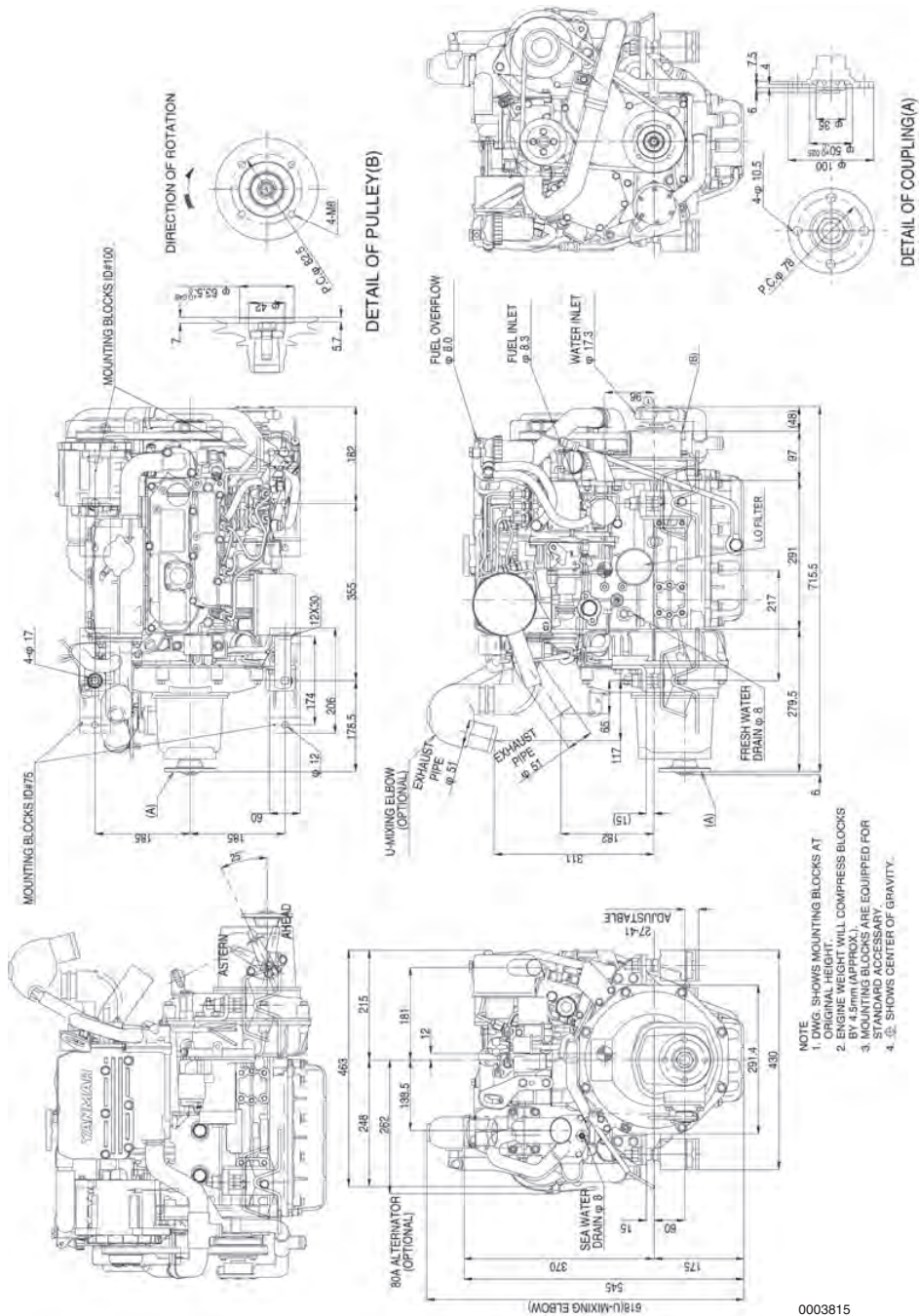
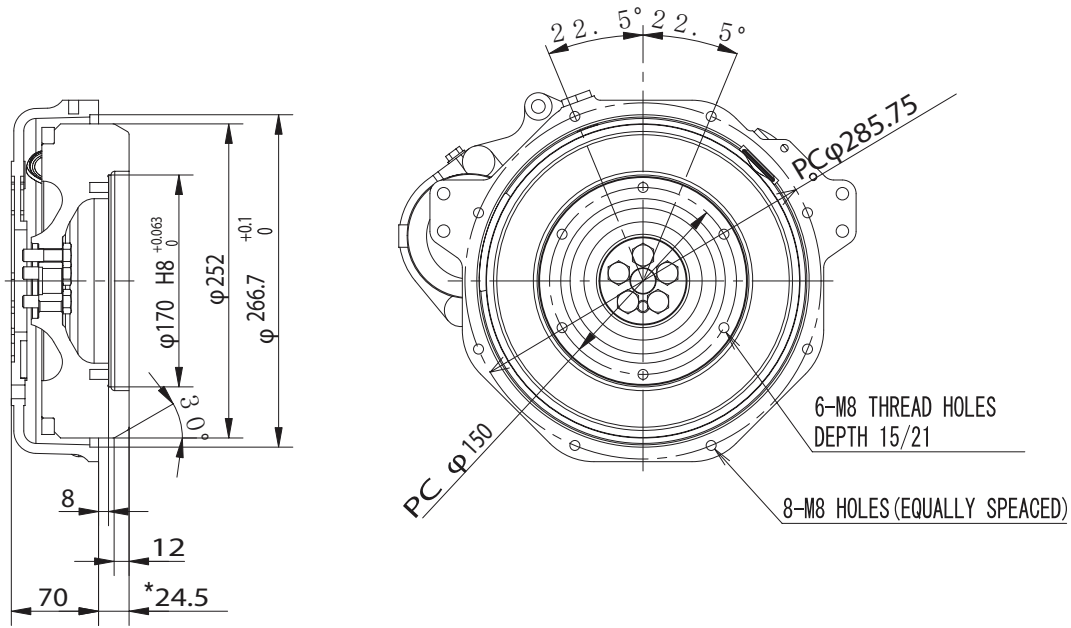

Figure -1

Unit: mm

Flywheel / Flywheel Housing Dimensions



Differs from GM series only in the dimension marked with *

0003806

Figure -3

Unit: mm

Piping Diagram

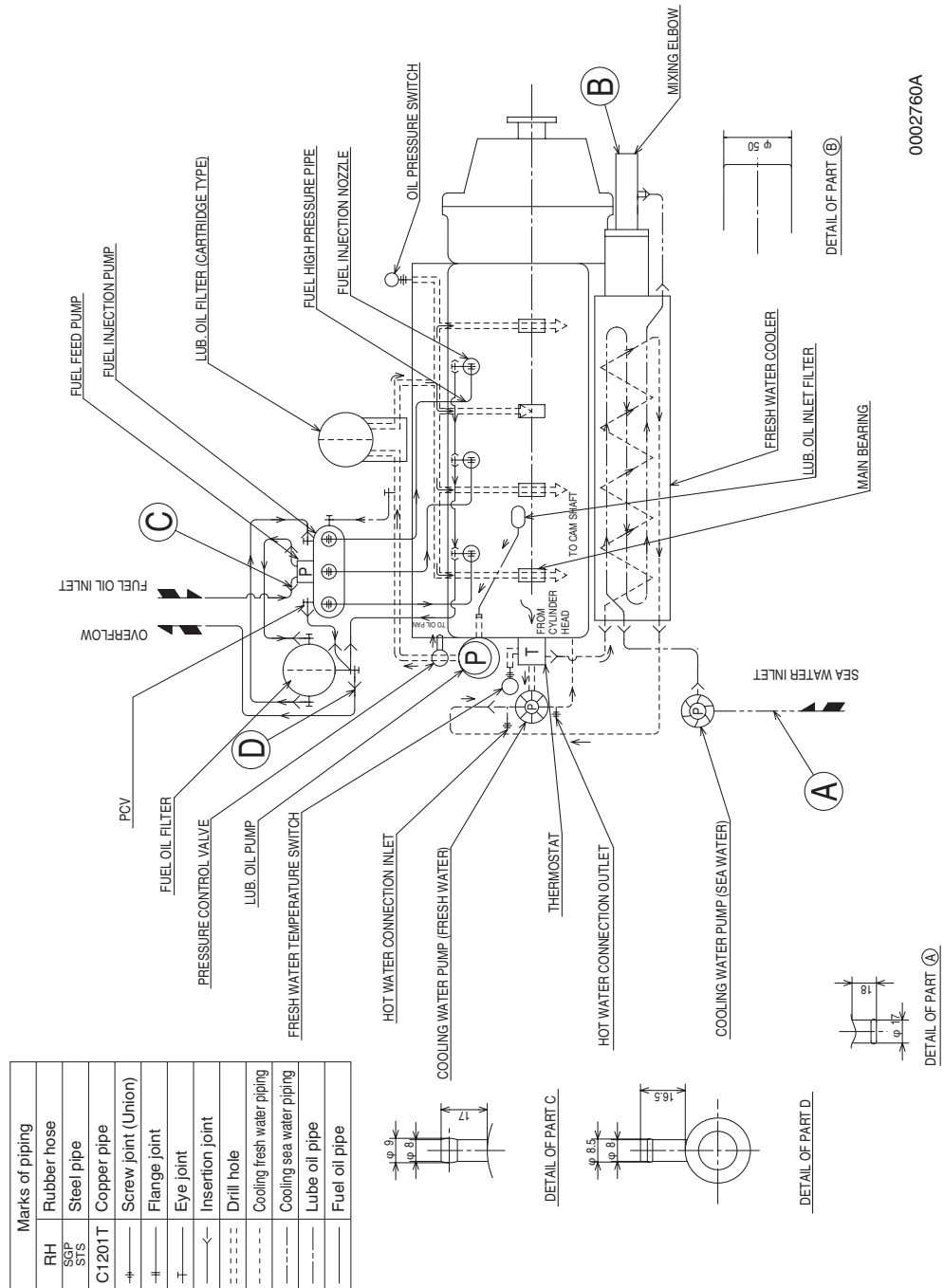

0002760A

Figure -4

Unit: mm

Electrical System

Starter Specifications

Parameter	Data
Yanmar Code	129608-77010
Starter Model	S114-817A (Hitachi)
Voltage	12 V
Output	1.4 kW (1.9 hp metric)
Direction of Rotation (Viewed from Pinion Side)	Clockwise
Weight	3.0 kg (6.6 lb)
Rating	30 seconds

Parameter	Data
Number of Pinion Teeth	11
No-load Terminal Voltage	11 V
No-load Maximum Current	90A (maximum)
No-load rpm	2700 (minimum)
Loaded Terminal Voltage	8.4 V
Loaded Maximum Current	250A
Loaded Torque	8.3 N·m (0.85 kgf·m) (6.12 lbf·ft) minimum
Loaded rpm	1000 (minimum)

Performance Curve for Starter

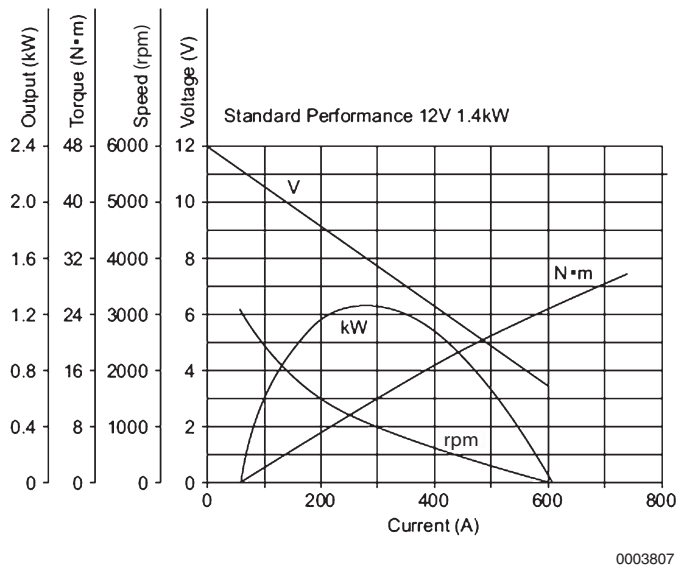
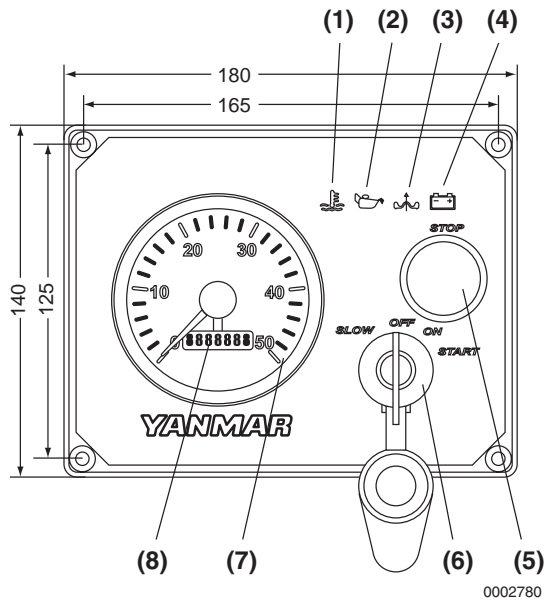

Figure -5

Panel

The 3YM30 uses the new B-type (VDO) panel.



- | | |
|--|----------------------------------|
| 1. Coolant High Temperature Alarm Lamp | 4. Battery Low Charge Alarm Lamp |
| 2. Engine Oil Pressure Alarm Lamp | 5. Engine Stop Lamp |
| 3. Water in Sail Drive Alarm Lamp | 6. Key Switch |
| | 7. Tachometer |
| | 8. Hourmeter |

Figure - 6

Standard Alternator Data

Parameter	Data
Yanmar Code	128271-77200
Alternator Model	LR160-741 (Hitachi)
IC Regulator Model	SA-A (Hitachi)
Battery Voltage	12 V
Nominal Output	12 V / 60A
Earth Polarity	Negative Earth
Direction of Rotation (Viewed from Pulley End)	Clockwise
Weight	4.2 kg (9.2 lb)
Rated Speed	5000 rpm
Operating Speed	1050 - 18,000 rpm
Speed for 13.5 V at 20°C (68°F)	5000 rpm
Output Current for 13.5 V	56A or more at 5000 rpm
Voltage Regulation at 20°C (68°F), Voltage Gradient, -0.01 V/°C	14.4 ± 0.3 V

Performance Curve for 60A Alternator

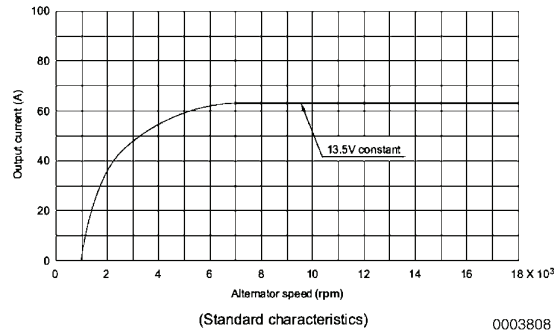

Figure - 7

Optional Alternator Data

Parameter	Data
Yanmar Code	119573-77201
Alternator Model	LR180-03C (Hitachi)
IC Regulator Model	TR1Z-63 (Hitachi)
Battery Voltage	12 V
Nominal Output	12 V / 80A
Earth Polarity	Negative Earth
Direction of Rotation (Viewed from Pulley End)	Clockwise
Weight	5.4 kg (11.9 lb)
Rated Speed	5000 rpm
Operating Speed	1200 - 9000 rpm
Speed for 13.5 V at 20°C (68°F)	1200 rpm
Output Current for 13.5 V	75A or more at 5000 rpm
Voltage Regulation at 20°C (68°F), Voltage Gradient, -0.01 V/°C	14.5 ± 0.3 V

Performance Curve for 80A Alternator

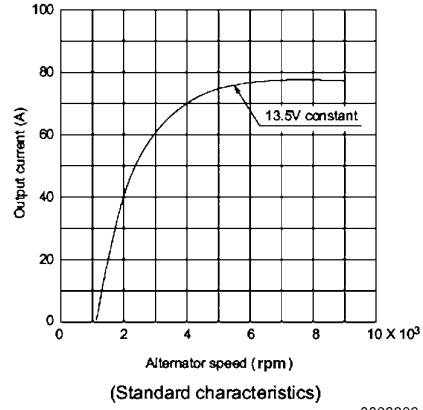

Figure - 8

Wiring Diagrams

Panel: B-Type (VDO)

Engine Models: 3YM30 / 3YM20 / 2YM15

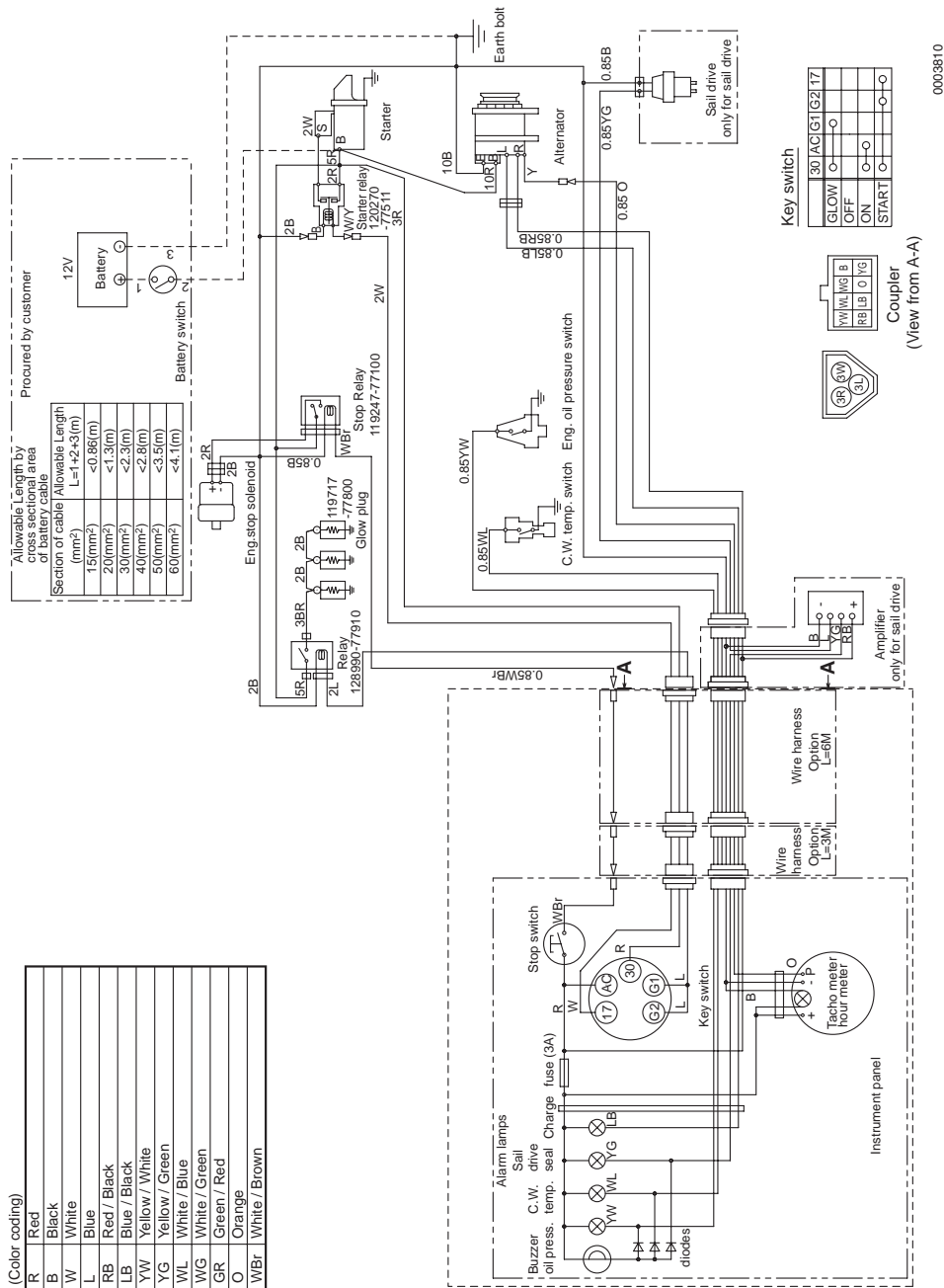
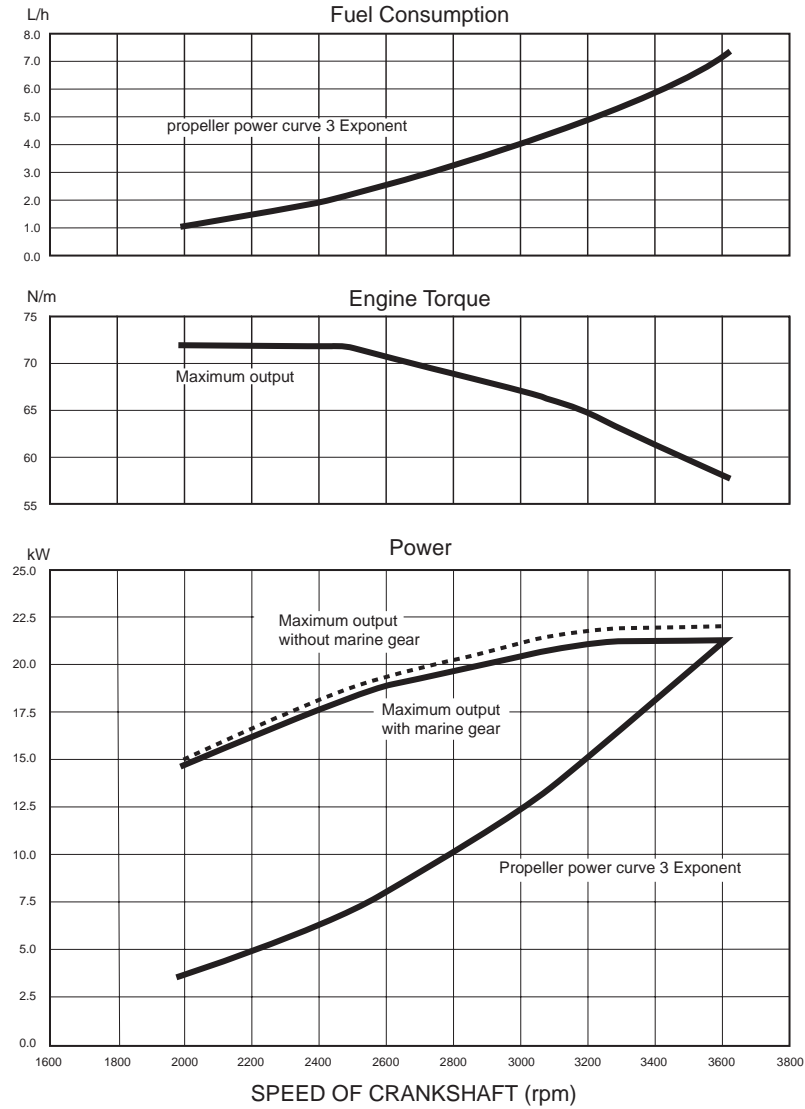

Figure -9

Performance Curves



(Note) Rating Condition: ISO 3046-1
 Fuel condition : Density at 15°C=0.842 g/cm³
 Fuel oil temperature : 25°C at fuel injection pump inlet

0003816

Figure -10

Controls

The 3YM30 uses a mechanical linkage to control engine speed and marine gear shifting. Electric stop solenoid is applied for engine stop.

Engine Speed Control (YPES-ML Fuel Injection Pump)

Recommended Remote Control Cable

Parameter	Data
Shift Cable Stroke	76.2 mm (3.0 in.)
Cable Connector Thread Size	M5* P0.8

Mechanical Controls (KM2P-1)

Recommended Remote Control Cable

Parameter	Data
Shift Cable Stroke	76.2 mm (3.0 in.)
Cable Connector Thread Size	10-32 UNF (See Figure -11)

Shifting Lever Force (Reference Value)		
Shifting Direction	Shift Lever Position at 56 mm (2.2 in.)	Remote Control Handle Position at 170 mm (cable length - 4 m [157.5 in.])
Engaging Force at Engine 1000 min ⁻¹	29.4 - 39.2 N (3 - 4 kgf) (6.6 - 8.8 lbf)	39.2 - 49.0 N (4 - 5 kgf) (8.8 - 11.0 lbf)
Disengaging Force at Engine 1000 min ⁻¹	34.3 - 49.0 N (3.5 - 5 kgf) (7.7 - 11.0 lbf)	39.2 - 58.8 N (4 - 6 kgf) (11.0 - 13.2 lbf)
Disengaging Force at Engine 1000 min ⁻¹ (KM2P-1 only)	39.2 - 49.0 N (4 - 5 kgf) (8.8 - 11.0 lbf)	49.0 - 58.8 N (5 - 6 kgf) (11 - 13.2 lbf)

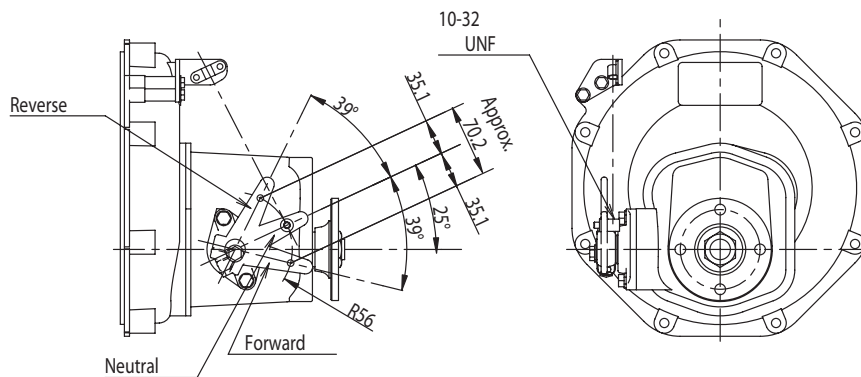

0003814

Figure -11

Unit: mm

Mechanical Controls (SD20)

Parameter	Data
Shift Cable Stroke	76.2 mm (3.0 in.)
Cable Connector Thread Size	10-32 UNF

Shifting Lever Force (Reference Value)	
Shifting Direction	Shift Lever Length 70 mm (2.75 in.)
Engaging Force at Engine 850 min ⁻¹	19.6 - 29.4 N (2 - 3 kgf) (4.4 - 6.6 lbf)
Disengaging Force at Engine 850 min ⁻¹	29.4 - 39.2 N (3 - 4 kgf) (6.6 - 8.8 lbf)

For Serial Number 2128 and before

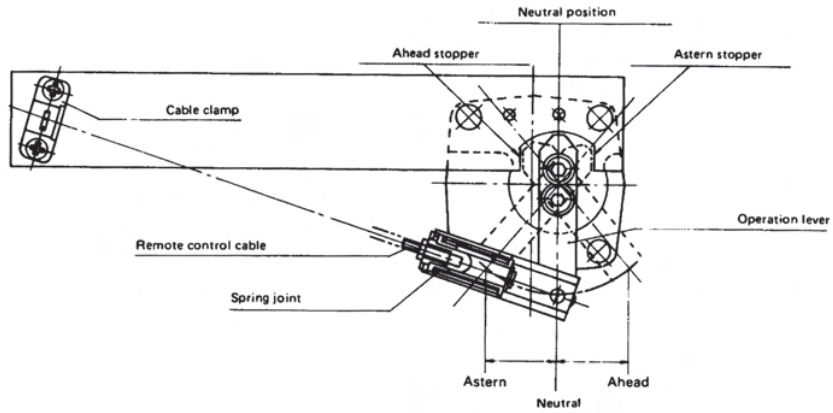

0003803

Figure -12

For Serial Number 2129 and after

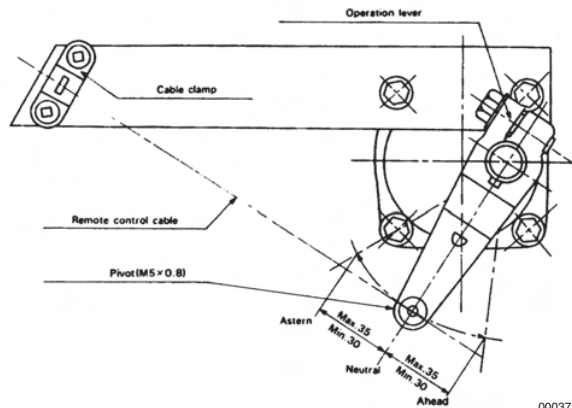

0003734

Figure -13

Unit: mm

Power Take-Off

The 3YM30 engine has front power take-off (PTO) capabilities.

Operating Condition:

1. A-type shows an example with an overhang distance (L) of 30 mm (1.182 in.). When the overhang distance differs in value, calculate the capacity with the following formula. (Limit of distance is 50 mm [1.97 in.]

$$\text{Allowable Take-Off Output} = \frac{140 \text{ mm}}{(L + 110) \text{ mm}} \times \text{kW}$$

L: Overhang distance (mm)

kW: Permissible Output

PTO Permissible Output Curve

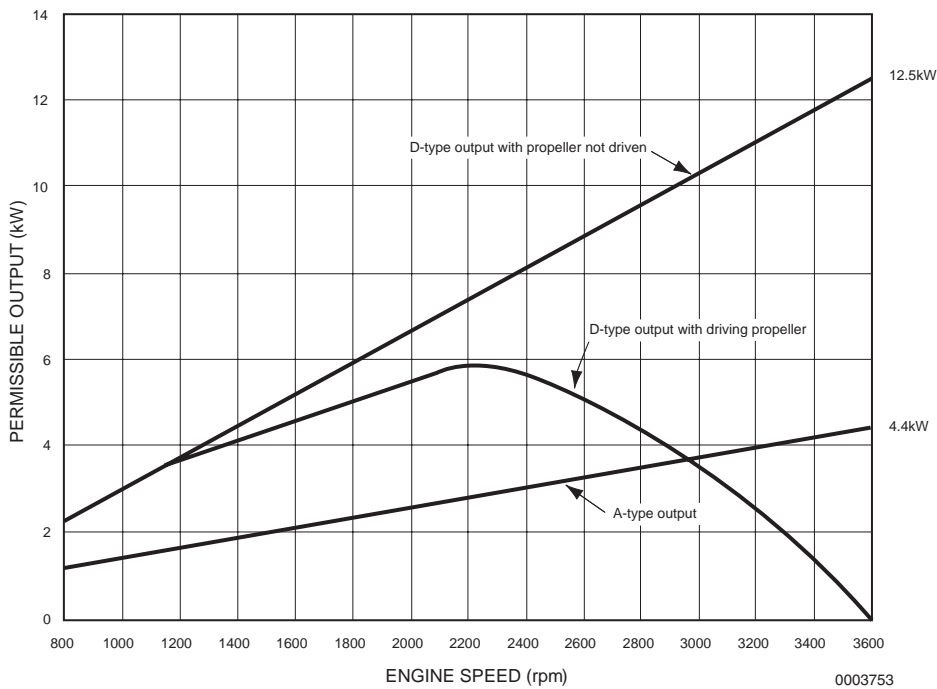

Figure -14

Engine Mount Specifications

Engine Mounts (with KM2P-1)

Parameter	Data
Position of Mount () Flexible Mount ID	(A), (B), (C), (D) 100, 100, 75, 75 (See Figure - 15)
Type of Flexible Mount	Fixed-1
Flexible Mount ID and Quantity	ID 75 x 2 ID 100 x 2 (See Figure -16)

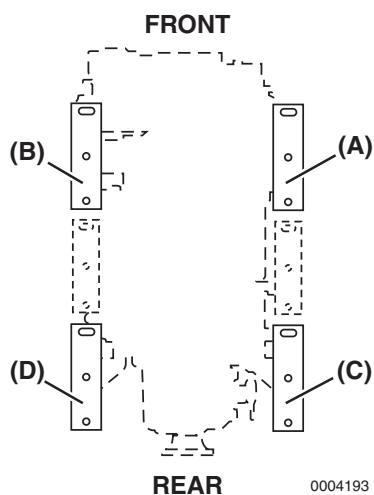
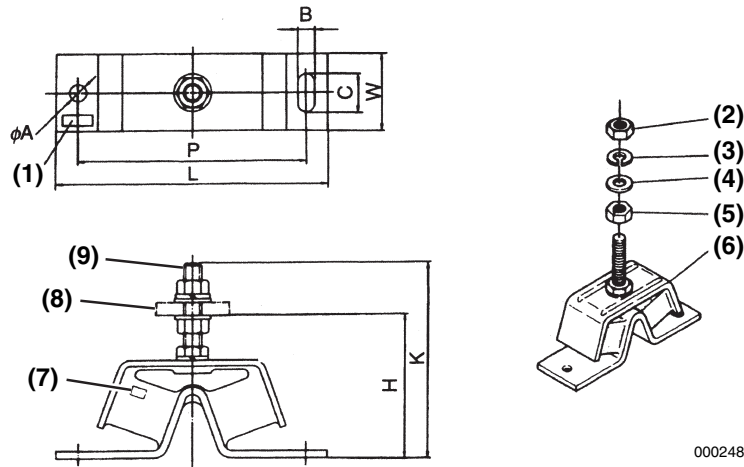

Figure - 15

Fixed-1 Type Engine Mount



0002484

- | | | |
|--------------------------|-----------------|------------------------|
| 1. ID Mark (Only ID 300) | 4. Flat Washer | 7. ID Mark |
| 2. Lock Nut | 5. Jack Nut | 8. Engine Foot |
| 3. Spring Washer | 6. Rubber Mount | 9. T (Thread Diameter) |

Figure -16

ID	H		K	L	P	W	Diameter A	B	C	T Thread Diameter
	Min	Max								
75	100 mm 3.94 in.	110 mm 4.33 in.	145 mm 5.71 in.	206 mm 8.12 in.	174 mm 6.86 in.	60 mm 2.27 in.	12 mm 0.48 in.	12 mm 0.48 in.	30 mm 1.19 in.	M16 X P1.5
100	100 mm 3.94 in.	110 mm 4.33 in.	145 mm 5.71 in.	206 mm 8.12 in.	174 mm 6.86 in.	60 mm 2.27 in.	12 mm 0.48 in.	12 mm 0.48 in.	30 mm 1.19 in.	M16 X P1.5

Engine Mounts (with SD20)

Parameter	Data
Position of Mount () Flexible Mount ID	(A) (B) 230, 100 (See Figure - 17)
Flexible Mount ID and Quantity	ID 230 x 1 ID 100 x 2 (See Figure - 17)

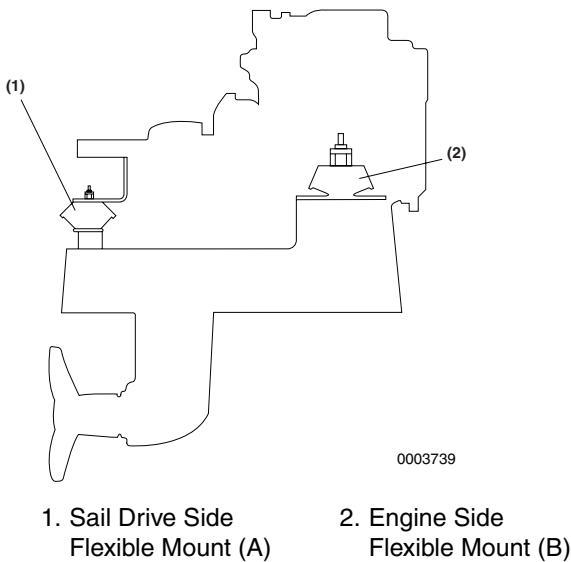

Figure - 17

Note: The shape of flexible mount (A) is different than (B). Flexible mount (A) is packed with SD20.

Flexible Mount Distortion

Parameter	Data
Static Distortion	4.5 mm (0.177 in.) approximate

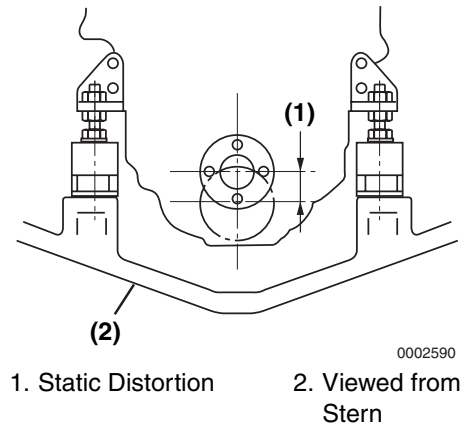

Figure - 18

Notes:

1. Engine weight will compress mounting blocks by the static distortion value.
2. Engine outline drawing shows mounting blocks at original height.

Cold Starting Aids

The 3YM30 engine is not equipped with cold starting aids.

Air Venting

The 3YM30 uses either a KM2P-1 marine gear or a SD20 sail drive, no venting device is needed.

Water Heater Tank Connection

The 3YM30 engine supports water heating tank connections for onboard head and galley operation.

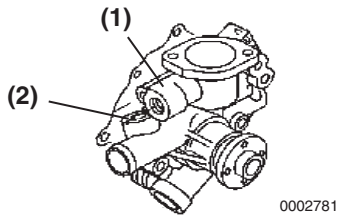

1. Water to Tank
2. Water from Tank

Figure - 19

Optional Accessories

The following is a list of the 3YM30 optional accessories.

- New B-type (VDO) panel
- New extension wire harness (EWN3)
- Battery switch (BS500)
- Side-mount single control head (MORSE: MV)
- Top-mount single control head (MORSE: MT3)
- Push-pull control cable (MORSE: 33C) (RC4, RC7)
- Propeller shaft half coupling, slit (CSG1)
- Propeller shaft half coupling, taper (CTG1, CTG2, CTG3, CTG4)
- Propeller shaft half coupling, straight (CRG1)
- Lube oil evacuation pump (EPP1)
- Electric-type bilge pump, 12 V (BP1)
- Seacock (K1, K2)
- Fuel tank 30 L (8 gal) (FT1)
- Alternator, 12 V - 80A
- U-type, water mixing elbow